



Mini 300 Power Supply

Cat. No. BT402

WARNING.....	3
SAFETY INFORMATION.....	3
ENVIRONMENTAL CONDITIONS.....	4
AVOIDING ELECTRICAL SHOCK.....	4
AVOIDING DAMAGE TO THE INSTRUMENT	4
EQUIPMENT OPERATION	5
SYMBOL.....	5
INTRODUCTION.....	6
OVERVIEW.....	6
PRODUCT DESCRIPTION & FEATURE.....	7
TECHNICAL SPECIFICATION	8
INSTALLATION INSTRUCTIONS.....	8
OPERATION INSTRUCTIONS	9
CONTROL INTERFACE.....	9
START THE OPERATION.....	9
TROUBLESHOOTING AND MAINTENANCE.....	11
ENCOUNTERING PROBLEMS	12
REPLACING THE FUSE.....	12
MAINTENANCE.....	13
WARRANTY	13
TECHNICAL SUPPORT	13

WARNING

BT Lab Systems Mini 300 Power Supply has been tested and found to comply with the limits for the CE regulation. Also, it is RoHS compliant to deliver confident product which meets the environmental directive. These limits are designed to provide reasonable protection against harmful interference when the instrument series is operated in a commercial environment. This instrument series used together with power supply unit generates, uses, and can radiate radio frequency energy, and if not installed and used in accordance with the instruction manual, may cause harmful interference to radio communications. Operation of this instrument series in a residential area is likely to cause harmful interference in which case the user will be required to correct the interference at their expense. Changes or modifications not expressly approved by the party responsible for compliance could void the user's authority to operate the equipment. It is strongly recommended for the user to read the following points carefully before operating this equipment.

1. Read and follow the manual instructions carefully.
2. Do not alter the equipment. Failure to follow these directions could result in personal and/or laboratory hazards, as well as invalidate equipment warranty.
3. Use a properly grounded electrical outlet with correct voltage and current handling capacity.
4. Disconnect from power supply before maintenance and servicing. Refer servicing to qualified personnel.
5. Never use this instrument series without having the safety cover correctly in position.
6. Do not use the unit if there is any sign of damage to the external tank or cover. Replace damaged parts.
7. Do not use in the presence of flammable or combustible material; fire or explosion may result. This device contains components which may ignite such materials.
8. Refer maintenance and servicing to qualified personnel.
9. Ensure that the system is connected to electrical service according to local and national electrical codes. Failure to make a proper connection may create fire or shock hazard.
10. Use appropriate materials and operate correctly to avoid possible hazards of explosion, implosion or release of toxic or flammable gases arising from overheated materials.
11. The unit shall be operated only by qualified personnel.

Safety Information

Use high level of precaution against any electrical device. Before connecting the electrical supply, check to see if the supply voltage is within the range stated at the rating label, and see to it that the device be seated firmly. Place the unit in a safe and dry location; it must NOT touch the surrounding. Follow the safety precautions for chemicals / dangerous materials. If needed, please contact qualified service representative or info@BTLabSystems.com.

Environmental Conditions

Ensure the instrument is installed and operated strictly under the following conditions:

1. Indoor use only
2. $\leq 95\%$ RH
3. 75-106 kPa
4. Altitude must not exceed 2000 meters
5. 4-40°C operating temperature
6. Pollution degree: 2
7. Mains supply voltage fluctuations up to $\pm 10\%$ of the normal voltage

Avoiding Electrical Shock

Follow the guidelines below to ensure safe operation of the unit.

The Mini 300 Power Supply has been designed to utilize shielded wires thus minimizing any potential shock hazard to the user. BT Lab Systems recommends against the use of unshielded wires.

To avoid electrical shock:

1. In the event of solution spilling on the instrument, it must be dried out for at least 2 hours and restored to NORMAL CONDITION before each operation.
2. Never connect or disconnect wires loading from the power jacks when the red indicator light of power switch is on.
3. WAIT at least 5 seconds after stopping a run before handling output leads or any connected apparatus.
4. ALWAYS make sure that your hands, work area, and instruments are **clean** and **dry** before making any connections or operating the power supply.
5. ONLY connect the power cord to a properly grounded AC outlet.

Avoiding Damage to the Instrument

1. Do not attempt to operate the device if damage is suspected.
2. Protect this unit from physical damage, corrosive agents and extreme temperatures (direct sunlight, etc.).
3. For proper ventilation and safety concerns, keep at least 10 cm of space behind the instrument, and at least 5 cm of space on each side.
4. Use high level of precaution against the damages on the unit.
5. Do not operate the unit out of environmental conditions addressed above.
6. Do not operate the power supplies in high humidity environments ($> 95\%$), or where condensation may occur.

7. To avoid condensation after operating the power supply in a cold room, wrap the unit in a plastic bag and allow at least 2 hours for the unit to equilibrate to room temperature before removing the bag and operating the unit.
8. Prior to applying any cleaning or decontamination methods other than manufacturer's recommendation, users should check with the manufacturer's instruction to see if the proposed method will damage the equipment.

Equipment Operation

Follow the guidelines below to ensure safe operation of the unit:

1. NEVER access dangerous chemicals or other materials to prevent possible hazard of explosion and damage.
2. Do not operate the unit without lids or covers to prevent possible hazards.
3. A temporary conductivity caused by condensation might occur even though this series is rated Pollution Degree 2 in accordance with IEC 664.

Symbol

Symbols used on the power supply are explained below.



Indicates an area where a potential shock hazard may exist.
Consult the manual to avoid possible personal injury or instrument damage.



Indicates disposal instruction.
DO NOT throw this unit into a municipal trash bin when this unit has reached the end of its lifetime. To ensure utmost protection of the global environment and minimize pollution, please recycle this unit.



Max. voltage: 300 V
Max. current: 400 mA
Max. watt: 60 W



This product has been tested to the requirements of CAN/CSA-C22.2 No. 61010-1, second edition, including Amendment 1, or a later version of the same standard incorporating the same level of testing requirements

THIS LIMITED WARRANTY SHALL NOT APPLY IF THE DEFECT WAS CAUSED THROUGH ANY OF THE FOLLOWING

1. The Product serial number or the accessory date code has been removed, erased, defaced, altered or is illegible; or
2. The defect is resulting from the use of the product in a manner other than their normal and customary manner, e.g., in excess of their minimum specification or operating instructions, or malfunction or failure resulting from use of incorrect voltages; or
3. Deterioration of the Product due to normal wear and tear. All plastic surfaces and other natural wear of externally exposed parts of the product are scratched or damaged under normal usage (including casing, key pad, display and accessories, etc.); or
4. The defect is arising from improper installation, unauthorized repair, alteration or modification to this product by third parties other than MS or its designee; or

5. The defect is arising from operating with components or accessories not officially authorized or provided by MS or used in other than its intended use; or
6. The defect was caused by unauthorized software including but not limited to ROM upgrades, non proprietary software; or
7. The defect or damage are arising from unauthorized modification of the operating software or caused by the computer virus; or
8. The defect or damage is arising from misuse, mishandling, accidental lost, abuse, accident, negligence and damage caused directly or indirectly by Customer, including but not limited to improper testing, installation, alteration or modification of any kind, or spillage of food or liquid, or build up of dirt or dust, or mains supply problem, thunderstorm activities, or infestation by insects or vermin, or exposure to abnormally corrosive conditions, or operation with extreme heat or humidity.

INTRODUCTION

Overview

BT Lab Systems Mini 300 Power Supplies are recognized as unique power supplies equipped with very powerful specifications to cover the majority of electrophoresis applications on the market. Sufficient and accurate output voltages, two terminal pairs, and its compacted size can deliver accurate and reliable experimental results from one experiment to another. Mini 300 Power Supplies are RoHS and CE compliant for environmental and safety concerns. Package offering is another feature for users' convenience and budget concern.



Front view

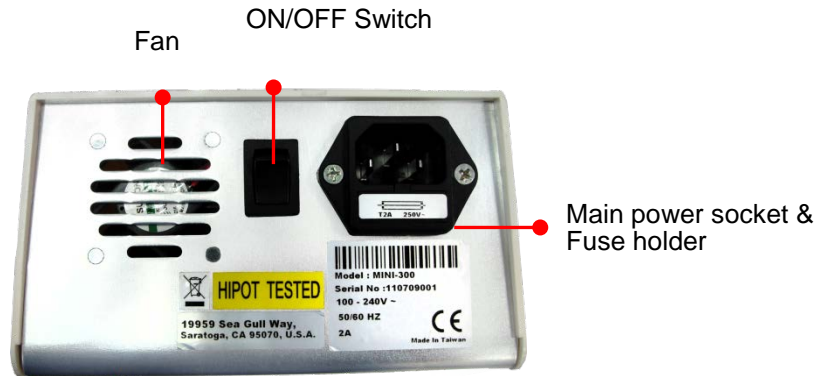

Rear view

Product Description & Feature

Combining small size and versatility, the newly redesigned Mini 300 power supply is an ideal choice for any researcher. Capable of providing constant current or constant voltage in 1 mA or 1 V steps, the unit is perfectly suited to run both vertical polyacrylamide and horizontal agarose electrophoresis experiments. Continuous or timed operations are easily performed using the simple and user-friendly interface. The Mini 300 power supply features 2 electrode pairs, allowing for 2 gels to be run simultaneously, saving both time and valuable bench space. With a universal voltage rating, the Mini 300 power supply is also designed and constructed to the most rigorous safety standards.

- Compact size
- Power capacity: 60W, 400mA, 300V
- Constant Voltage or Constant Current operation
- 1 V step voltage selection; 1 mA step current selection
- Timer
- No load detection
- Shrouded plugs and sockets
- Two pairs of outlet terminals
- Output voltage stability
- Economic choice for larger horizontal electrophoresis & 10 x 10 cm vertical electrophoresis
- New housing and exterior design

TECHNICAL SPECIFICATION

Cat. No	BT402
Output Voltage / Inc.	Step 1: 10 - 300V / 1V Step 2: 0, 10 - 300V / 1V
Output Current / Inc.	Step 1: 10 - 400mA / 1mA Step2: 0, 10 - 400mA / 1mA
Max. Watt	60W
Output Type	Constant Voltage or Constant Current
Control	Microprocessor controller
Terminal Pairs	2 Pairs
Timer	1 - 999 minutes with alarm, continuous
Program	2-step program
Preset Value	Step 1: V: 300V; A: 16mA; T:15min Step 2: V: 300V; A: 24mA; T: 120min
Safety Device	No load detection; shrouded plugs and sockets
Operation Temperature	4-40°C
Unit Dimension	140 x 191 x 84mm
Construction material	Polycarbonate housing and aluminum bottom plates
Weight	Approx. 1 kg
Rated Voltage	100 - 240 V~, 50-60Hz, 2A
Certification	ETL, CE, FCC



INSTALLATION INSTRUCTIONS

Mini 300 Power Supply is actually a pre-installed instrument. As long as it is placed on a sturdy and level surface in a safe, dry place, and further connects with well-prepared electrophoresis system, it is ready for operation.

OPERATION INSTRUCTIONS

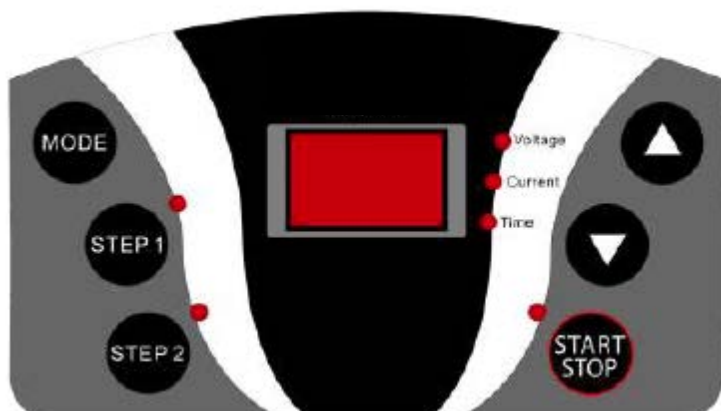
Control interface

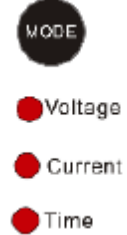

	Two step buttons are available. Press STEP 1 and STEP 2 buttons to switch between the steps
	Press MODE to switch setting mode among Voltage , Current and Time . LED lights indicate your current status.
	Press to increase or decrease the selected parameter
	Start stop the operations

Start the operation



Note: To operate under constant voltage or constant current modes, adjust the other parameter to the maximum value. For example, to operate under constant voltage, adjust current to max before running using constant voltage, and vice versa.



1. Place the unit on a sturdy and level surface in a safe, dry place, away from laboratory traffic.
2. Ensure that the AC power switch is OFF, and then plug the three-pronged power cord into a grounded three-prong AC outlet with appropriate voltage (100V to 240V as indicated on the rating sticker near the AC cord on the back of the unit).
3. Connect the DC output jacks from the electrophoresis unit; insert the red lead (+) into the red output jack, and the black lead (-) into the black output jack.

4. Power on the unit by pressing the ON/OFF switch.
5. Press **STEP 1** or **STEP 2** to enter desired step
6. Press **MODE** to switch between Voltage, Current and Time
7. Adjust the output value by pressing the up and down arrows.
***NOTE:** When timer is set to "0" the unit will run at constant operation.*
***NOTE:** To operate under constant voltage or constant current modes, adjust the other parameter to the maximum value. For example, to operate under constant voltage, adjust current to max before running constant voltage, and vice versa.*
***NOTE:** If you need only one STEP, set parameters of STEP2 zero. System will run STEP 1 without proceeding to STEP 2.*
8. When the run is completed, Press Start/Stop Key to terminate a timed run, and Turn the AC power OFF by the switch on the rear.
9. The programmed settings will be automatically saved into the system so the next time you turn it on, the same settings as your previous experiment will be displayed.

TROUBLESHOOTING AND MAINTENANCE

Many operating problems may be solved by carefully reading and following the instructions in this manual accordingly. Some suggestions for troubleshooting are given below. Should these suggestions not resolve the problem, contact our SERVICE DEPARTMENT or a distributor in your region for assistance. If troubleshooting service is required, please include a full description of the problem.

Problem	Cause	Solution
No Display / lights	No AC power	Check if the power supply is unplugged, or AC power source problem
	AC power cord is not connected	Check AC power cord connections at both ends. Use the correct cords.
	The fuse has blown	Replace the fuse
Repeated fuse broken	Hardware failure	Contact BT Lab Systems service department
Operation stops	Electrophoresis leads are not connected to the power supply or to the electrophoresis unit(s), or there is a broken circuit in the electrophoresis cell	Check the connections to the power supply and on your electrophoresis cell to make sure the connection is intact; check condition of wires in electrophoresis unit. Close the circuit by reconnecting the cables. Press START/STOP to restart the run.
	High resistance due to tape left on a pre-cast gel, incorrect buffer concentration, or incorrect buffer volumes in the electrophoresis cell	Correct the condition by making sure the tape is removed from the pre-cast gel, buffers are prepared correctly, and the recommended volume of buffer is added to the electrophoresis unit.
 Error message	Over current(400mA limitation reached)	Check if the buffer concentration is appropriate. Excessive buffer concentration may cause over current issue. To clear the error message, press the START/STOP button again
 Error message	Over voltage(300V limitation reached)	Press START/STOP button to clear the error message. Contact MS service dept. if the problem persists.

 Error message	Thermal limitation reached(Output voltage <10V)	(1) Check the connections (2) If Er3 error message persists, the problem may be caused by internal fan failure. Contact MS service department.
 Message	No load is detected	(1) Check the connections (2) Check the buffer condition / buffer level
 Alarm message	Max. watts(60W) of power reached	Warning message for reference

Encountering Problems

1. Check the troubleshooting section.
2. Call Technical Service or e-mail to info@BTLabSystems.com
3. If the unit must be shipped back for repair, contact BT Lab Systems or the distributor for a Return Authorization Number and shipping instructions. The unit will be repaired and returned to you as quickly as possible.

Replacing the Fuse

For additional fuses, contact BT Lab Systems co. ltd.

To replace the fuse:

1. Turn off the main power switch at the rear of Power Supply and detach the power cord.
2. Open the fuse compartment located inside the Power Entry Module by inserting a small flat blade screwdriver into the slot below the ON/OFF switch. Turn the screwdriver to gently pry open the fuse compartment.
Note: The fuse compartment will not open with the power cord in place.
3. Pull the fuse holder out of the compartment and inspect the fuse. If the fuse is burned or there is a break in the fuse element, replace the fuse with an identical type of fuse (**T2AH250V**) as provided in the fuse holder (see figure below).
4. Place the fuse holder back into the compartment.
5. Snap the cover closed.

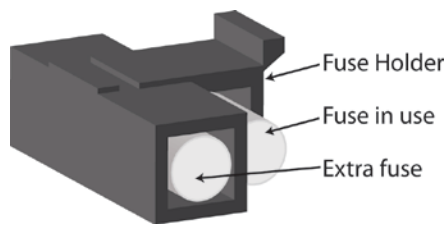

Maintenance

Mini 300 Power Supply uses all solid-state components and should require no maintenance or recalibration under normal use. If the unit must be returned for repair, contact our **SERVICE DEPARTMENT** or your local distributor for shipping instruction.

WARRANTY

BT Lab Systems warrants apparatus of its manufacture against defects in materials and workmanship, under normal service, for ***one year from the shipping date to purchaser***. This warranty excludes damages resulting from shipping, misuse, carelessness, or neglect. BT Lab Systems's liability under the warranty is limited to the receipt of reasonable proof by the customer that the defect is embraced within the terms of the warranty. All claims made under this warranty must be presented to BT Lab Systems within one year following the date of delivery of the product to the customer.

TECHNICAL SUPPORT

BT Lab Systems offers technical support for all of its products. If you have any questions about the product's use or, operation, please contact BT Lab Systems at the following info.

E-Mail: info@BTLabSystems.com