



A Geno Technology, Inc. (USA) brand name

# **Benchtop Vertical Laminar Flow Hood**

---

**Cat. No. BT2501**

Thanks for choosing BT Lab Systems Benchtop Vertical Laminar Flow Hood.

Please read this manual carefully before operating the instrument to ensure proper use and avoid serious injuries. Failure to comply with these instructions, maintenance, and storage conditions may result in damage and void the warranty.

### **Important Information**

Immediately upon receipt of the equipment, please inspect for damage. If there is any, please take photos of both the damage to the equipment and the damage to the outer packaging and email [info@btlabsystems.com](mailto:info@btlabsystems.com) to report the issue.

### **Disclaimer**

BT Lab Systems is not liable for equipment failure or for any indirect/direct damage that may occur during its use.

- Damage or malfunction resulting from non-compliance with the guidelines, safety precautions, and intended usage outlined in this manual.
- Damage or malfunction resulting from any repairs or modifications by unauthorized third parties.
- Damage or malfunction resulting from the simultaneous usage of instruments manufactured by other companies.
- Damage or malfunction resulting from operation in an environment that does not comply with the specified conditions, including power supply and installation requirements.
- Damage or malfunction resulting from natural disasters, including but not limited to earthquakes and floods.
- Damage or malfunction resulting from the relocation or transport of the equipment post-installation, of which the company was not informed.

## INTRODUCTION

The vertical laminar flow hood offers sample protection by directing purified air in a vertical, unidirectional stream across the working zone and out of the open front, creating a sterile work area suitable for aseptic processing. This versatile flow hood is ideal for a wide range of laboratories and industries, ensuring superior cleanliness in life sciences, medical, electronics manufacturing, and other fields. Its benchtop design allows for placement on laboratory workbenches, making it ideal for compact work areas.

Application:

- Microbiology (non-pathogenic)
- Forensics
- Sterile product compounding

## KEY FEATURES

- LCD, Microprocessor control system.
- Air speed adjustable, HEPA filter, and sterilization lamp replacement reminder function.
- HEPA filter with efficiency: 99.995% at 0.3 $\mu$ m.
- The pre-filter is polyester fiber, washable, and antioxidant.
- UV sterilization system.
- With memory function in case of power failure.
- Interlock function: UV lamp only can be switched on when the front window is closed, ensuring operator safety.
- UV timer: When the setting time expires, the UV lamp automatically switches off in preparation for the next experiment.

## TECHNICAL SPECIFICATIONS

### Basic Parameters

Model	BT2501
External Size (WxDxH)	710 x 680 x 1050mm (without base stand) 710 x 680 x 1670mm (with base stand)
Internal Size (WxDxH)	610 x 590 x 625mm
Work Surface Height	750mm
Airflow Velocity	0.2 – 0.5m/s
Pre-Filter	Polyester fiber, Washable
HEPA Filter	≥99.995% efficiency at 0.3μm
Windows	Front and Side windows, 5mm toughened glass, anti-UV
Display	Microprocessor controlled with LCD, graphical, and digital display of the operating status of each function
Material	Main Body: Cold-rolled steel with anti-bacteria powder coating
	Worktable: 304 stainless steel
Sound Emission	≤62dB(A)
UV Lamp	8W x 1pcs, Emission of 253.7 nanometers
LED Lamp	8W x 1pcs
Caster	Universal caster with leveling feet
Max. Consumption	800W
Power Supply	AC220V±10%, 50/60Hz or 110V±10%, 60Hz
Standard Accessory	UV Lamp, LED Lamp, and Waterproof Socket
Optional Accessory	BT2501-A; Base Stand
Net Weight	80kg (without base stand)
	130kg (with base stand)
Gross Weight	115kg (without base stand)
	165kg (with base stand)
Shipping Size (WxDxH)	850 x 936 x 1218mm

**NOTE: BT Lab Systems reserves the right to change future product designs without notifying its users.**

### Vibration amplitude

The maximum vibration amplitude does not exceed 5μm in the frequency range from 10Hz to 10kHz.

### Illumination

The average lighting level exceeds 350 lux.

### Electrical Properties

The laminar flow hood is designed to withstand a rapid increase in voltage up to 1390V (AC) within a 5-second period without breaking down, ensuring it remains operational under sudden voltage surges. Moreover, it is constructed to maintain a grounding resistance of ≤0.1 ohms, contributing to its overall safety and stability when in use.

### ***Normal Operating Conditions***

- This product is for indoor operation only.
- Ambient Temperature: 15°C – 35°C
- Relative Humidity: ≤75%
- Atmospheric Pressure Range: 70kPa – 106kPa

### ***Operating Environment***

- The laminar flow hood must be placed in an area protected from air streams.
- The working area of the laminar flow hood should not be near doors, windows, or air outlets to prevent interference from ventilation systems, air conditioning, and personnel.
- **There must be a minimum of 300mm gap on the side and back of the Laminar flow hood for inspection purposes.**
- The rated electrical outlet load must not be lower than the demand and must provide adequate power supply to the laminar flow hood.
- Power Supply must be grounded.

Judging Method: Test the socket's live and neutral wire with a multimeter device.

The voltage between the live and ground wire should equal the voltage of the local electrical grid, and the voltage between the neutral and ground wire should equal 0. Otherwise, the power supply is not grounded.

## STRUCTURE

### *Air Cleaning System*

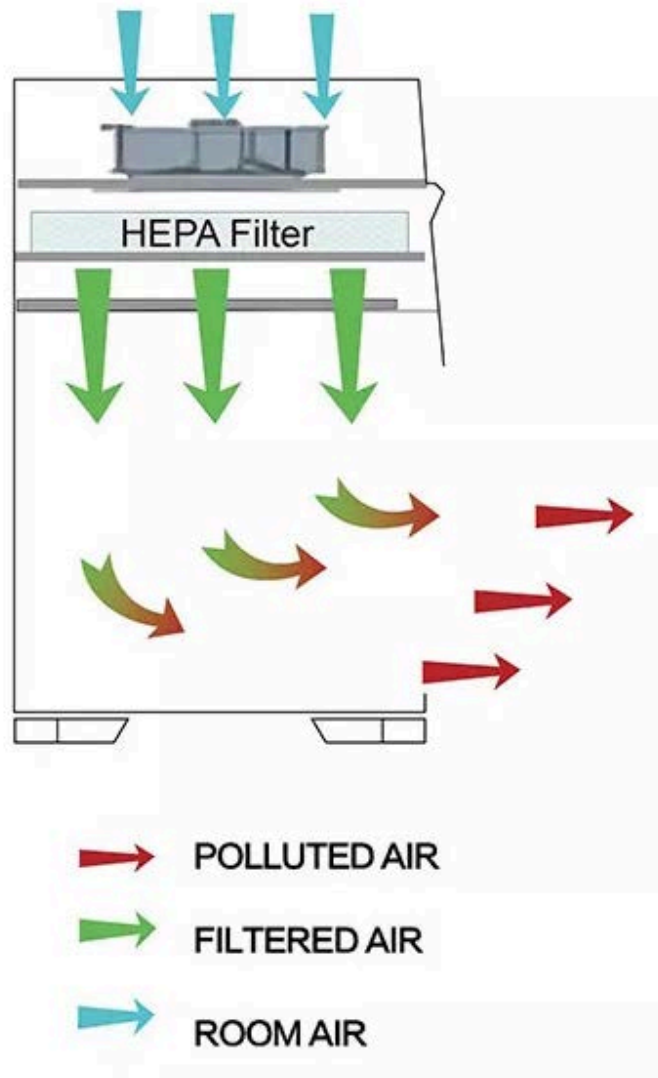

## Overview

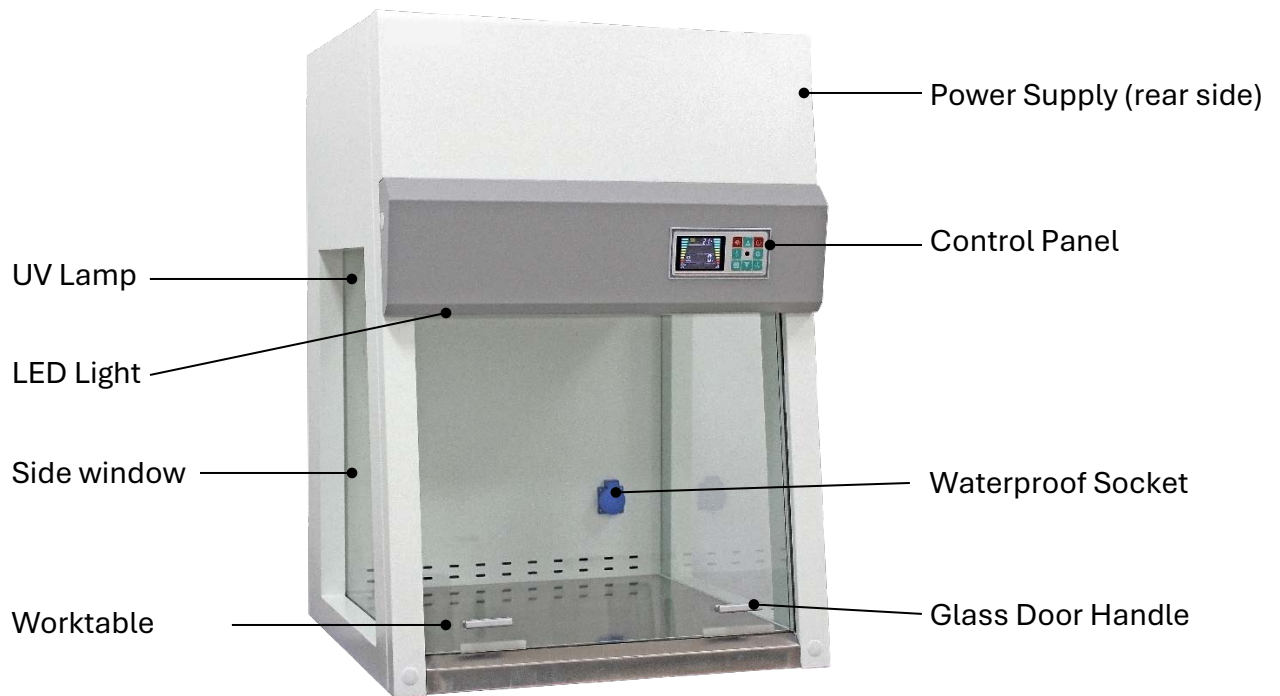

### Waterproof Socket

A waterproof socket has been installed in the operating area, providing optimal convenience for small devices inside the laminar flow hood.

Press the **[Socket]** icon on the control panel to open and close the cover.



#### **NOTE**

- **The total load must be  $\leq 500W$**
- **The waterproof socket is only waterproof when the front cover is closed. The socket should not be considered waterproof if the front cover is open.**

## Control Panel Display

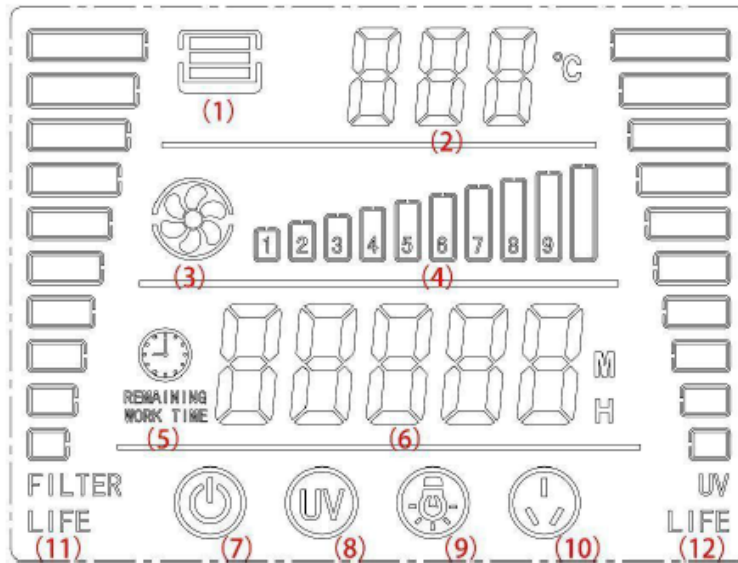

1. Glass Panel Door Status  
Open – The outer frame of the icon and 2 bars light up  
Closed – Entire icon is lit up
2. Current ambient temperature is displayed while in running mode.  
When in the password input interface, “PA” is displayed.  
When in parameter setting mode – the English abbreviation of the corresponding parameter is displayed.
3. Fan Icon
4. Fan Speed – displays the set fan speed
5. Timer Icon
6. Time Status  
Running Mode – The cumulative running time of the fan is displayed  
UV Sterilization Mode—The remaining time of sterilization is displayed. When sterilization is complete, it will display as “End”
7. Power Icon – displays when the power is off
8. UV Sterilization Icon – flashes when in UV Sterilization mode
9. Lights Icon – displays when lighting is on.
10. Socket Icon – displays when the power supply is turned on
11. Filter Life
12. UV Lamp Life



## Control Panel Keypad

There are 2 different keypad styles. Refer to the below for each button function.

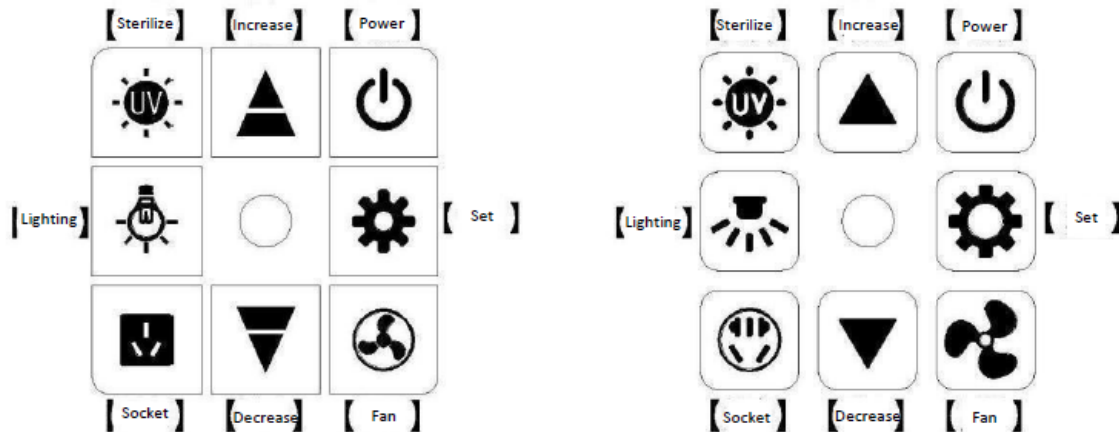

## Key Functions

<b>[Power]</b>	Powers equipment on or off
<b>[Lighting]</b>	Turns the lights on or off
<b>[Socket]</b>	Opens or closes the waterproof socket
<b>[Sterilize]</b>	Press and hold [Sterilize] for 3 seconds when the door, lighting, and fan are all closed to turn on the UV Sterilization lamp.
<b>[Fan]</b>	Turns the Fan on or off
<b>▲   ▼</b>	<p>Increase and decrease</p> <ul style="list-style-type: none"> <li>When the fan is turned off, increase or decrease the fan speed parameter.</li> <li>When the fan is on, directly increase or decrease the fan speed.</li> <li>When setting parameters or entering in the password, increase or decrease the values.</li> </ul>
<b>[Set]</b>	<ol style="list-style-type: none"> <li>Press [Set] to enter the password input interface.</li> <li>Use the increase/decrease keys to modify the password value, then press [Set] again to access the parameter setting interface.</li> <li>Once in the parameter setting interface, press [Set] to cycle through the settings and adjust the parameters using the increase/ decrease keys.</li> <li>Press and hold [Set] for 3 seconds to save the settings and exit.</li> </ol>

## Interlocking Function

- The fan can only be turned on when the glass panel door is open.
- To initiate the sterilization process, ensure the glass panel door is closed, and turn off the lighting, socket, and fan.

## Sterilization Time Setting

When in the parameter setting mode, “UT” will be displayed. Modify the values using the increase/decrease keys, then press [Set] to save and exit.

## INSTALLATION

- Before removing the packing material, move the equipment to the location where it will be installed.



**If a base stand is purchased together with the benchtop vertical laminar flow hood, the base stand will be packed at the back of the main body. Please remove it before installation. Do not invert, disassemble, or tilt the flow hood during transportation.**

- Remove all packaging materials, then check the surface of the main body to ensure there is no damage
- Confirm receipt of all component parts according to the packaging list.

### ***Base Stand Assembly***

1. Remove the hexagon socket head bolts from both ends of the cross-bracing bars and from all sides of the T-shaped frame.
2. Align the frames and bars together, then tighten the screws. Additionally, fasten the nuts on both sides of the base frames.
3. Adjust the leveling caster at the foot to slightly adjust the height
  - a. Clockwise – lowers the leveling caster and height of the cabinet. Base stand is fixed into place.
  - b. Counterclockwise – raises the leveling caster and height of the cabinet. Base stand is moveable.

### ***Main Body to the Base Stand Installation***

1. Place the laminar flow hood on top of the base stand, aligning the positioning bolts of the stand with the mounting holes of the flow hood.
2. Lead the bolts through the base and side panels from bottom to top, then firmly fasten securing the body to the base stand.
3. After completing the above steps, move the laminar flow hood slightly to the correct position, disconnect the power cord, and check its integrity.

### ***Inspection after installation***

Ensure that the voltage and frequency match the nameplate. Then, check the following items with the power on:

1. Lift the glass panel door up and down to ensure it runs smoothly.
2. Check for normal working conditions and operation is consistent with set parameters:
  - a. Fan Motor – Running normally
  - b. LED Lamp – Lamp light turns on after pressing key
  - c. UV Lamp – Lamp light turns on after pressing key
  - d. Control Panel Keys – All buttons work
  - e. Socket – Use a multimeter to test voltage output after pressing the socket key

For any questions, please email [info@btlabsystems.com](mailto:info@btlabsystems.com) for additional assistance.

## EQUIPMENT PRECAUTIONS

1. Ensure that the input voltage is correct and stable. The rated load of the main power socket should be higher than the laminar flow hood consumption. The plug must be well grounded.
2. The weight of items placed in the flow hood should not exceed 23kg for an area of 25×25cm<sup>2</sup>.
3. Avoid vibration: Do not use vibrating equipment, such as centrifuges, vortex oscillators, etc., inside the flow hood, as it can lower cleanliness in the operating area and affect operator protection.
4. No open flames are allowed inside the flow hood. Using fire can disrupt airflow and damage filters. If sterilization is required, an infrared sterilizer is recommended.
5. HEPA filter life: Dust and bacteria accumulate inside the HEPA filter over time, causing an increase in filter resistance. When the resistance reaches its maximum point, and the required speed cannot be met, replacement filters can be purchased separately through BT Lab Systems. The used filter should be disposed of according to Federal, State, and local regulations.
6. The steel plate under the fan is strictly sealed in the factory. Operators are not allowed to remove or loosen the screws on these parts.
7. The maximum storage period is one year. If the period exceeds one year, a performance test should be conducted.
8. Regularly check the UV lamp. Replace it when the total working time reaches 600 hours or when the intensity is lower than the requirement.

## PRE-OPERATION GUIDELINES



### **IMPORTANT NOTICE:**

BT Lab Systems will take no responsibility for risks caused by improper operation and man-made damages!

1. Connect to a suitable power supply.
2. Perform quick test of parameter operations to ensure functions are working properly.
3. Sterilize the laminar flow hood using the UV lamp for at least 30 minutes with the glass panel door fully closed before conducting any experiment.
4. Adjust the glass panel door to the appropriate height above the worktable and turn on the fan. Wait for at least 30 minutes while the fan is running before starting the experiment.
5. Place the experiment materials inside the flow hood before starting the experiment.
6. When moving different samples inside the flow hood, ensure that low-polluting samples are not placed near high-polluting samples. The movement of items should be slow and steady.
7. After completing the experiment, fully close the glass panel door and sterilize the cabinet with the UV lamp for 30 minutes before turning it off.

### ***Safety Caution***

- Ensure that people leave the room during UV sterilization to protect their eyes and skin.

## EQUIPMENT CARE, MAINTENANCE, AND STORAGE

The recommended interval for comprehensive maintenance is either one year or 1000 working hours.

### ***Daily Cleaning***

Clean the surface using a soft cotton cloth soaked in concentrated liquid soap. Then, wipe off the foam using another cloth or towel soaked in clean hot/warm water. Finally, dry the surface using a dry cotton cloth or towel.

For contaminated or dirty surfaces, use 70% rubbing alcohol or a disinfectant that will not damage the 304 stainless steel.

Use a soft cotton cloth or towel with a non-abrasive household cleanser to clean the external surface and front window.

### ***Preventative Maintenance***



**When performing maintenance, please pay attention to cutting off the power to avoid electric shock.**

### **Daily or Weekly**

- Disinfect and clean the operating area.
- Clean the external surface and front window around the operating area.
- Check the various functions of the laminar flow hood.
- Record the maintenance results.

### **Monthly**

- Clean the external surface and front window.
- Use a towel with 70% rubbing alcohol or 1:100 dilution of household bleach to wipe the working table, the front window's inner face, and the working area's inner wall surface (excluding the top wind grid). Use another towel with sterile water to wipe those areas to remove the remaining chlorine.
- Check the various functions of the laminar flow hood.
- Record the maintenance results.

### **Annually**

- Check the two lifting belts of the front window tubular motor, ensuring that both are well connected to the motor with the same tightness.
- Check the UV lamp and LED light.
- Apply an overall performance test of the laminar flow hood annually to ensure that the safety meets requirements. The user is responsible for testing costs.
- Record the maintenance results.

**Storage**

- The laminar flow hood should be stored in a warehouse with a relative humidity of not more than 75% and a temperature lower than 40°C.
- The warehouse should have good ventilation performance without acid, alkali, or other corrosive gases.
- The storage period should not exceed one year. Laminar flow hoods stored for over a year must be unpacked and checked before selling and using.

**ADDITIONAL ACCESSORIES**

Optional accessories for the Benchtop Vertical Laminar Flow Hood can be purchased separately.

<b>Cat. #</b>	<b>Description</b>
BT2501-A	Base Stand
BT2501-B	Replacement Pre-Filter
BT2501-C	Replacement HEPA Filter

## TROUBLESHOOTING

Before diagnosing any issues, please ensure the following: the power supply is properly connected, the cord is not damaged, the fuse is intact, and the circuit is not tripped. Also, confirm that the power lock is unlocked.

Issue	Possible Cause	Troubleshooting
Fluorescent lamp does not work	Control board malfunction	Check the control board located inside of the front panel
	LED stand not plugged in	Secure the connection of the plug and stand
	Defective LED stand	Replace LED stand
	Faulty control panel	Replace control panel
UV lamp does not work	Interlocking function	Confirm glass panel door is fully closed, and the lights and fan are off
	Lamp is not secured	Tighten lamp and ensure proper fit
	Control board malfunction	Check the control board located inside of the front panel
	Defective ballast	Replace ballast
	Lamp burnout	Replace UV lamp
	Faulty control panel	Replace control panel
	Defective micro switch	Check if the micro switch is broken
Key button does not work	Faulty control panel	Replace control panel
Blower does not work	Defective micro switch	Check if the micro switch is broken
	Motor failure/damaged fan	Replace fan
	Control board malfunction	Check the control board located inside of the front panel
	Faulty control panel	Replace control panel
Equipment does not start/ no power	Faulty control panel	Replace control panel
	Defective Transformer	Check condition of the transformer
Display does not light up	Connection winding displacement	Confirm the connection cable is secure
	Display screen defective	Check the condition of the display screen
	Faulty control panel	Replace control panel



**NOTE:**

- The troubleshooting methods mentioned should be carried out by a qualified electrical technician under safe conditions, with the power supply cut off. No other components should be removed.
- Any risk resulting from failure to follow these instructions will be the responsibility of the user.
- If the cause cannot be identified or resolved, please email [info@btlabsystems.com](mailto:info@btlabsystems.com) for additional technical assistance. Do not attempt to repair or troubleshoot the equipment without a trained and qualified electrical technician.

To order replacement parts, please email [info@btlabsystems.com](mailto:info@btlabsystems.com) and include the catalog number and serial number of the laminar flow hood.

***Replacing the Fuse***

The fuse is located on the plug power socket. Using a flat-head screwdriver, pop the fuse box out. Check the condition of the fuse and replace it if necessary.

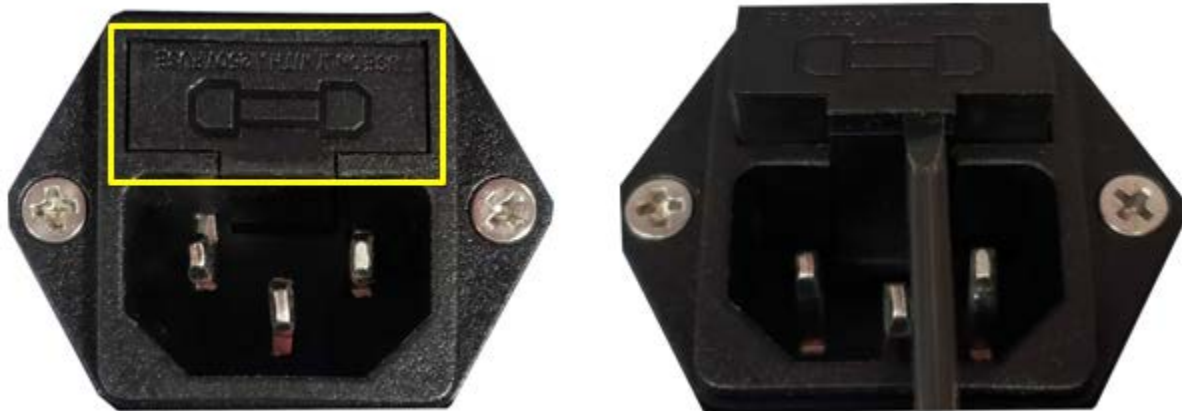

### Replacing the Fluorescent Light

When the fluorescent light needs to be changed, turn off the power. Detach and unplug the LED stand and replace it with the new LED stand.



### Replacing the UV Lamp

The UV lamp lifespan provided with the product is for a cumulative working period of 600 hours.

To ensure effective disinfection, we recommend regularly testing the UV light intensity using a UV intensity test card. This will help determine if it's necessary to replace the UV lamp.

When replacing the UV disinfection lamp, make sure to turn off the power supply, unscrew the UV lamp, remove it from the lamp holder, and replace it with a new UV disinfection lamp.

### WIRING DIAGRAM

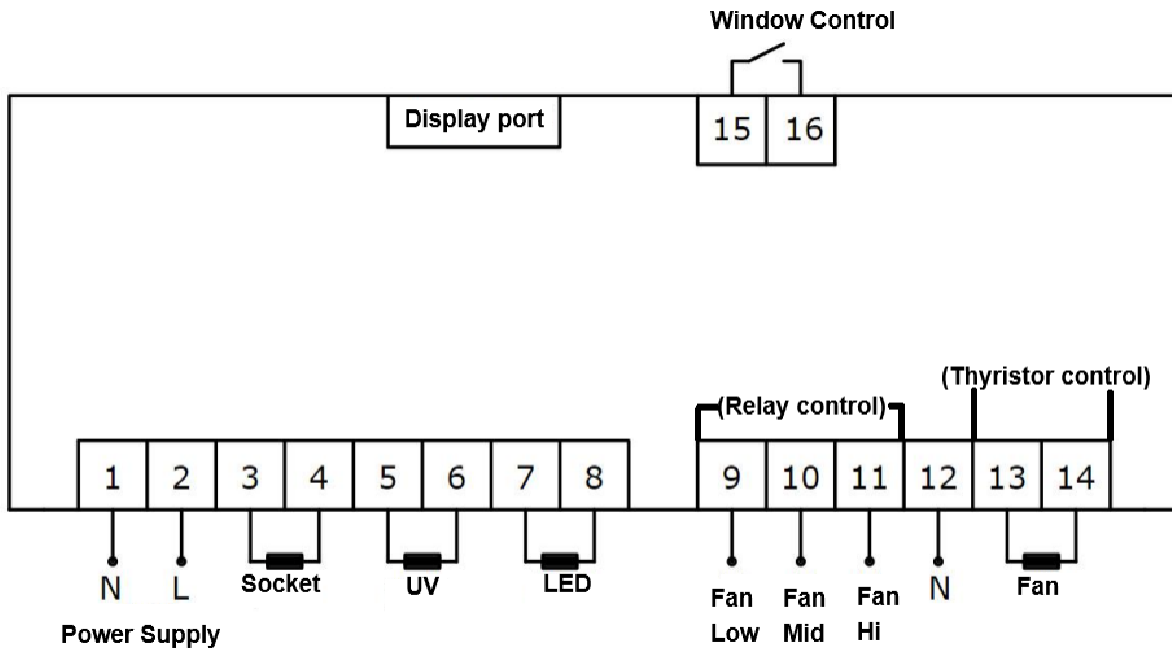

## WARRANTY

The warranty for this product is 36 months from EX-factory date (excluding the UV lamp, filters, and fluorescent lamp). This warranty does not apply to platinum wire and all the accessories.

BT Lab Systems will not be liable for damages caused by the following:

1. Damage caused by accident, misuse, or abuse.
2. Damage caused by disaster.
3. Repair or modification by anyone else without our authorization.
4. Corrosion due to the use of improper solvent or sample.
5. Defects caused by improper operation.
6. Use of fittings or other spare parts supplied by different manufacturers.

## TECHNICAL SUPPORT

BT Lab Systems' laminar flow hoods undergo thorough inspection and testing for quality and performance before leaving the facility.

If you encounter any issues during operation, please email a video of the problem to [info@BTLabSystems.com](mailto:info@BTLabSystems.com). Our engineers will then provide you with steps or a video on how to resolve the issue. Equipment drawings and technical data can also be provided for maintenance companies or personnel trained by our engineers.