

Thermal Cycler, 384 Well Gradient

Cat. No. BT2010

OUT OF BOX AUDIT	3
WARRANTY	3
WARRANTY COVERAGE.....	3
IMPORTANT SAFETY OPERATION INFORMATION.....	3
INTRODUCTION.....	4
FEATURES.....	4
SPECIFICATIONS	5
NORMAL WORKING CONDITIONS.....	5
BASIC PARAMETERS AND PERFORMANCE.....	5
BASIC OPERATING INSTRUCTIONS.....	6
STRUCTURE	6
OPERATION GUIDE.....	6
START UP.....	6
RUN FILE OPERATION.....	7
GRADIENT CALCULATION.....	9
USER MANAGEMENT	10
SYSTEM SETTINGS.....	10
ASSISTANCE.....	11
FAULT ANALYSIS AND PROCESSING	11
ANNEX A WIRING DIAGRAM OF GRADIENT PCR INSTRUMENT	12
ANNEX B THERMAL CYCLER, 384 WELL PACKING LIST.....	13
ANNEX C THERMAL CYCLER, 384 WELL TEST STATEMENT	14
TECHNICAL SUPPORT	14

Thanks for choosing BT Lab Systems Thermal Cycler, 384 well Gradient. This operation manual describes function of the instrument. To ensure that you could operate instrument in correct way, please read the manual carefully before first using it. Please keep this manual properly for later use if you meet any difficulty.

OUT OF BOX AUDIT

At the first time of opening the packing, please check the instrument and appendix with the packing list. If anything does not match with the packing list, please contact us.

WARRANTY

The instrument is warranted against defects in materials and workmanship for 1 year. If any defects occur in the instrument or accessories during this warranty period, BT Lab Systems will repair or replace the defective parts at its discretion without charge.

For any inquiry or request for repair service, contact your local BT Lab Systems office. Inform BT Lab Systems of the model and serial number of your instrument.

WARRANTY COVERAGE

Breakdown due to improper use, operation in inappropriate conditions, maintain or refitting without authorization are not in warranty coverage.

Repair after warranty will be charged at reasonable cost.

IMPORTANT SAFETY OPERATION INFORMATION

- The user needs to have a complete understanding of how the instrument will work before operating the instrument safely. Before operating the instrument, please read this manual carefully.
- Use a neutral soap solution to clean the holes in the base. Do not use strong bases, concentrated alcohols and organic solvent solutions
- There should be no other articles under the machine and its left and right cooling Windows. After the machine is used for a period of time, some dust will adhere to the heat dissipation window, which should be cleaned up in time. This step is essential.
- The module should be cleaned frequently. Once some reactant residues are accumulated in the module cavity, it will affect the temperature response. It is recommended to wipe it regularly with cotton cloth.
- This product is an indoor using instrument
- The operator should not attempt to open or repair the instrument, which would void your warranty and may result in an electric shock. In case of repair, contact BT Lab Systems.
- Before connecting the power supply, make sure that the voltage of the power supply matches the voltage required by the instrument. And make sure that the rated load of the power outlet is not less than the requirements of the instrument.
- If the power cord is broken, it must be replaced. Replacement must be replaced with a power cord of the same type and size. Do not press anything on the power cord when the instrument is in use. Do not place the power cord where people are moving.

- Hold the plug with hands when plugging and unplugging the power cord. When inserting the plug, make sure that the plug is fully inserted into the socket. Do not pull the power cord when pulling out the plug.
- This instrument should be placed in a place with low humidity, little dust and far away from water source and avoid direct sunlight and strong light source. The room should be well ventilated and free from corrosive gas or strong magnetic field interference. Keep away from heating, stove and other heat sources. Do not place the instrument in damp or dusty places.
- The power should be turned off when the device stops working. When the device is not used for a long time, the power plug should be removed, and the device should be covered with a soft cloth or plastic paper to prevent dust from entering.
- Unplug the instrument from the electrical outlet immediately under the following conditions and contact the supplier or have it attended by trained service personnel:
 - There is liquid spilling inside the instrument.
 - The instrument is exposed to rain or water
 - The instrument is not working properly, especially if there are any abnormal sounds or smells.
 - The instrument is dropped, or the casing is damaged.

INTRODUCTION

The Thermal Cycler, 384 Well is a compact gradient PCR machine for gene amplification. It has 5-inch TFT high-definition true-color full-touch LCD screen, display the entire program in real-time with curved graphs, and the parameter modification is intuitive and convenient. It uses the latest generation of semiconductor technology, has excellent temperature accuracy and its uniformity ensure high quality experimental results.

FEATURES

- Unique appearance, compact size with interface operation simple and convenient.
- Built with latest generation of semiconductor technology, excellent augmentation performance, effectively eliminate the edge effect of module heat conduction, the module temperature uniformity is excellent
- Built-in multi-channel refrigeration film, several sensors are evenly distributed, the program temperature control is precise.
- 5-inch TFT high-definition full-touch color screen, can quickly edit the required files, visual display of temperature curve, convenient and fast setting, accurate display of temperature curve and instrument running process status in real time.
- The system has a built-in gradient calculator, which can easily obtain accurate annealing temperature for different experimental samples to optimize PCR reaction conditions.
- Come with User login, password protection, data security, administrators can clear data not required, large data storage, the maximum number of files that can be stored in the machine is greater than 100.
- The ingenious elastic hot cover structure design, adapts to the different height test tube, guarantees the best conditions for the test.
- Real-time display of gradient temperature distribution, real-time temperature display, more conducive to controlling the sample temperature.

- The hot lid temperature and working mode can be set, hot lid can be switched on and off.
- Test tube temperature control mode and module temperature control mode can be chosen to meet more different experimental requirements.

SPECIFICATIONS

Normal working conditions

- Ambient temperature: 5°C ~ 30°C
- Relative humidity ≤70%
- Power Supply: 100~240V AC 6.6~3.1A 50/60Hz

Basic parameters and performance

Model	BT2203	Hot cover temp. range	30 ~ 110°C
Single step time range	1-59m59s (0 is forever)	Max. steps of the program	30
Temp. range	4-99.9°C	Program max. cycle number	99
Sample capacity	384×0.04ml	Time increment/decrement	-599 ~ +599s
Max. heating rate	4.5°C/s	Temp. increase/decrease	-9.9 ~ +9.9°C
Max. cooling rate	4°C/s	Program pause function	Yes
Temp. uniformity	±0.20°C	16°C Insulation	Forever
Temp. accuracy	±0.10°C	LCD	5 inch, 800×480 Pixel
Temp. display resolution	0.1°C	Program storage quantity	> 100
Temp. control method	Block\Tube	Communication Interface	USB 2.0
Gradient temp. uniformity	±0.2°C	Input power	100~240V AC 6.6~3.1A 50/60Hz
Gradient temp. accuracy	±0.2°C	Dimensions(W*D*H)	W.185×D.280×H.160mm
Gradient temp. range	30-99.9°C	Net weight	4.3kgs
Gradient temp. difference range	0.1-30°C		

BASIC OPERATING INSTRUCTIONS

This section introduces the structure of the instrument and the basic operation of the instrument, as well as preparations before starting the machine. When using the instrument for the first time, you should be familiar with this section before starting up.

Structure

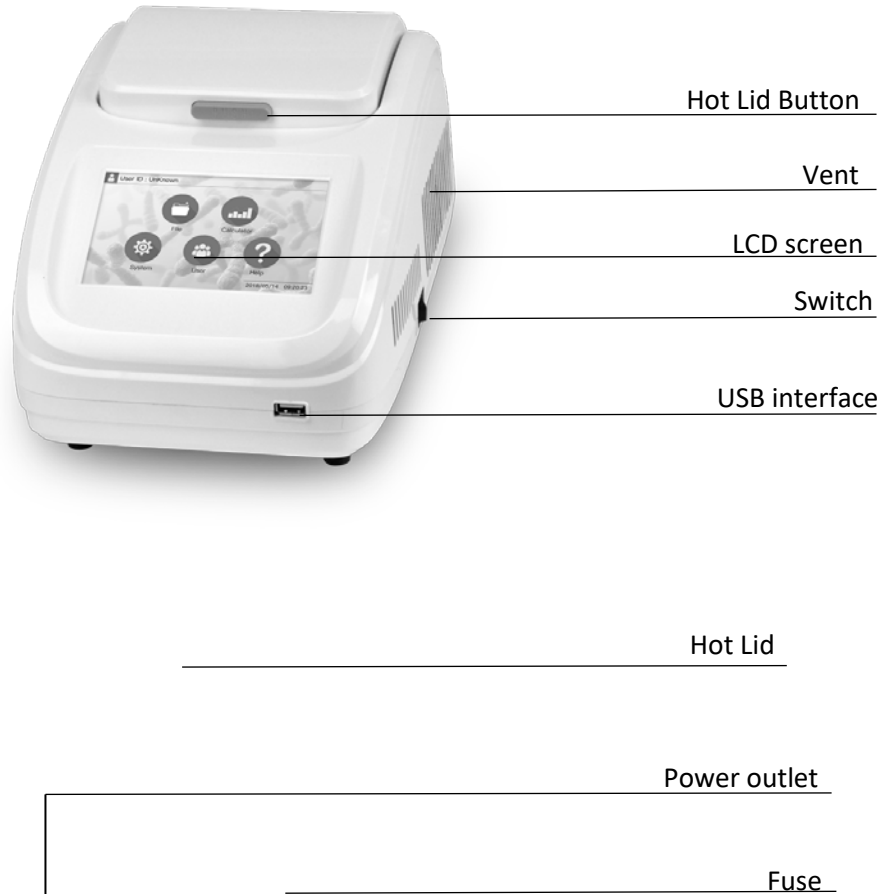

OPERATION GUIDE

Start up

After the instrument is powered on, press the power switch, the LCD screen lights up, and the instrument enters the welcome screen (see Figure 1). In the welcome screen, the LCD screen displays the product name. After the welcome screen, enter the main menu interface (see Figure 2).



Figure 1



Figure 2

Run file operation

The running file is the PCR amplification program. The running file consists of the temperature step and the cycle step. Each file can contain up to 30 steps.

1. File library

Click the “File” icon in the main interface to enter the file library interface. The left column shows the file list, the right side shows the specific file information and file preview of the selected file, and the bottom is the function button. When a file is selected, the file can be edited, deleted, and renamed (see Figure 3), Insert the USB disk before power-on, the interface displays "USB Storage", press this button after selecting the file to export the file to the USB disk, please restart the instrument after the operation

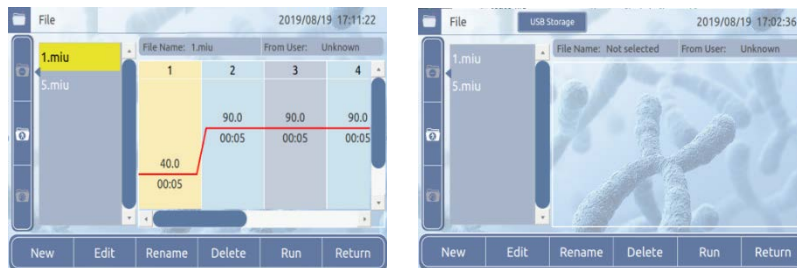

Figure 3

2. Create a new file

- a. Click "New" to enter the new editing interface. Above the temperature curve is the temperature, below is the time, click on the temperature or time to set its parameters by the number keys (see Figure 4). Click the "+Step" button and the "+Cycle" button to add temperature steps and cycle steps. (The maximum number of steps is no more than 30).

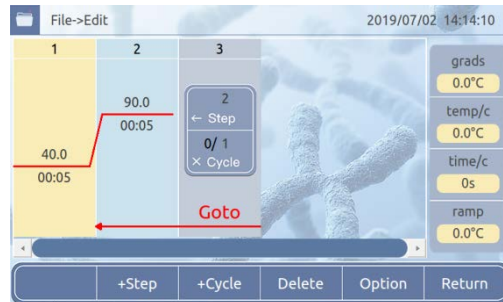

Figure 4

- b. After the parameter setting is completed, click the "Return" button to pop up the save dialog box, click "OK", input is completed, as shown in Figure 5(1), enter the file name in the "Name" box, click "OK", see Figure 5(2), return to the file library interface, at this point the file is newly created.



Figure 5(1)



Figure 5(2)

3. Edit file

- a. Select the file to be edited in the file library, click the "Edit" button to enter the editing interface, the temperature is on the top of the temperature curve and time is below the temperature curve. Click temperature or time to set its parameters through the number key (see figure 6). Click the "+Step" button and the "+Cycle" button to add temperature steps and cycle steps. (The maximum number of steps is no more than 30).

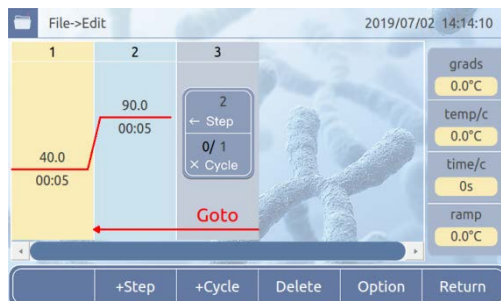

Figure 6

- b. Select a temperature step and click the “Option” button to set detailed parameters for this temperature step, including “Temp”, “Time”, “+Temp/c”, “+Time/c”, “Grads”. After the setting is completed, click “OK” to return to the editing interface (see Figure 7). Click "Return" to return to the editing interface, and the parameters are not updated.



Figure 7

4. Running file

- a. Select the file to be run in the file library, click “Run” to enter the running interface, and click “Lid Off” or “Lid On” to switch the hot cover. The list on the right side of the graph shows the hot lid and module temperature, the current step time, and the total time. Click “Run” and the file will start running (see Figure 8).

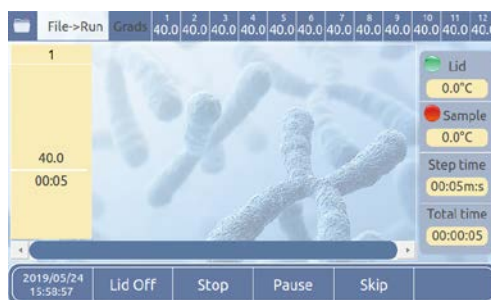

Figure 8

- b. When the file runs at a certain step, the temperature curve will flash, indicating that it is running; during the operation, you can click “Pause”, pause the operation, click “Continue” to continue running; click “Skip” to skip the next run; click "Stop", stop running.
- c. After the running file time is over, enter the low temperature storage state, and the Total time displays complete. Click “stop” to stop the operation.

Gradient calculation

- a. Click the “Calculator” icon in the main interface to enter the gradient calculation interface (see Figure 9).



Figure 9

- b. Click on the corresponding area and enter the module temperature and gradient range. After the input is completed, click “OK” to automatically calculate the temperature of each sample tank. Click "Return" to return to the main interface.

User Management

- a. Click the “User” icon in the main interface to enter the user list of the user management interface (see Figure 10).

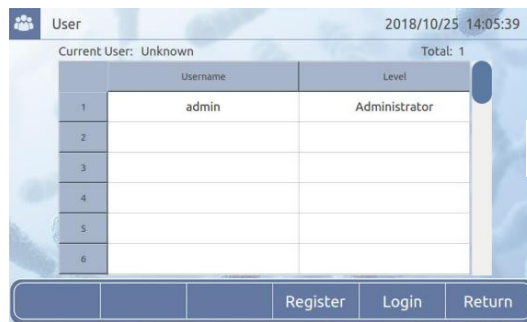

Figure 10

- b. Click “Register”, enter the registration interface, enter the username, password and other information, click "Ok" to complete the registration.
- c. Click “Login”, enter the login page, enter the corresponding information, and complete the login.

NOTE: Log in as "Admin" can delete other users.

System settings

Click the “System” icon in the main interface to enter the system settings interface (see Figure 11). After the setting is completed, click “Ok” to save the settings; click “Return” to return to the main interface.



Figure 11

Assistance

Click the "Help" icon in the main interface to enter the help interface (see Figure 12). Insert the USB disk before power-on, the interface displays the "Import File" button, click this button to switch to the import interface, select the file on the import interface and click the Import button to import the file to the current user. "Refresh" is used to refresh the file library. Restart the instrument after the operation.



Figure 12

FAULT ANALYSIS AND PROCESSING

Fault analysis and processing method

No.	Error message	Possible causes and corresponding countermeasures
1	Display Error Open:x Short:x	Sensor open circuit or short circuit, return to factory for maintenance
2	Display screen not bright and abnormal	Hardware failure, return to factory for maintenance
3	Touch failure	Hardware failure, return to factory for maintenance
4	Block is not heated	Hardware failure, return to factory for maintenance
5	Block temperature is too high / too low	Hardware failure, return to factory for maintenance
6	Hot cover is not heated	Hardware failure, return to factory for maintenance
7	Hot cover temperature is too high	Hardware failure, return to factory for maintenance
8	fan cannot rotate	Hardware failure, return to factory for maintenance

ANNEX A WIRING DIAGRAM OF GRADIENT PCR INSTRUMENT
(Below diagram is just for reference. It is subject to change without prior notice.)

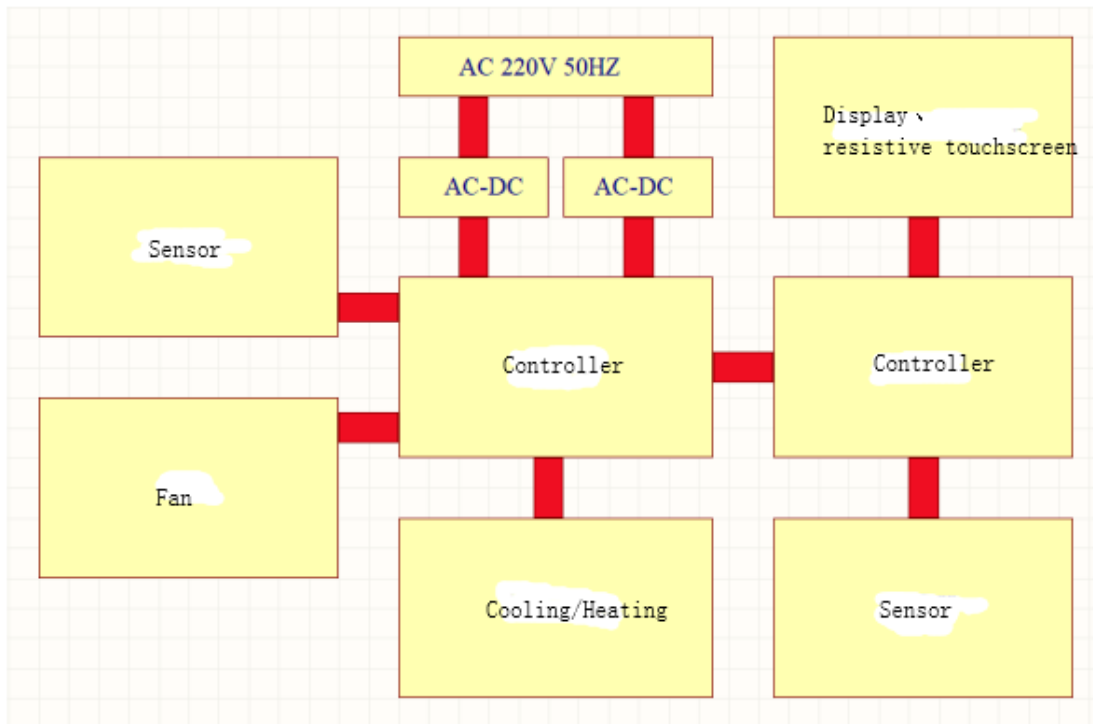

ANNEX B THERMAL CYCLER, 96 WELL PACKING LIST

No.	Name	Type	Unit	Qty	Remarks
1	Thermal Cyclor, 384 Well	BT2010	Set	1	
2	Power Line		EA	1	
3	Touch Pen		EA	1	
4	Performance Test Statement		EA	1	
5	Operation Manual		EA	1	
6	Warranty card		EA	1	
Charger: (Sign/Stamp)			Packing Date:		

ANNEX C THERMAL CYCLER, 96 WELL TEST STATEMENT

Name	Thermal Cycler, 96 Well	Type	BT2203	
Test Date		Production No.		
No.	Test Content	Test Methods	Standard	Conclusion
1	Basic Function	Visual Inspection	Valid	<input type="checkbox"/> Qualified
2	Appearance	Visual Inspection	Valid	<input type="checkbox"/> Qualified
3	Outer Marks	Visual Inspection	Valid	<input type="checkbox"/> Qualified
4	Continuous Work Test	Experiment	72 Trouble Free	<input type="checkbox"/> Qualified
Test Results:				
Tester:		Confirmer :		

TECHNICAL SUPPORT

BT Lab Systems offers technical support for all of its products. If you have any questions about the product's use or, operation, please contact BT Lab Systems at the following info.

E-Mail: info@BTLabSystems.com